

MicroMACS6

Hardware Reference

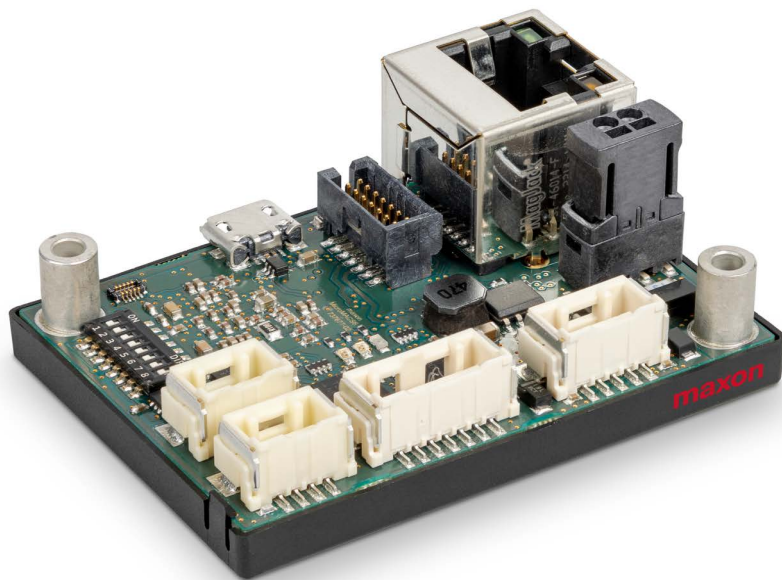

CANopen[®]
EtherNET



TABLE OF CONTENTS

1	ABOUT	5
1.1	About this document	5
1.2	About the device	7
1.3	About the safety precautions	8
2	SPECIFICATIONS	9
2.1	Technical data	9
2.2	Limitations.	10
2.3	Dimensional drawings.	11
2.4	Standards	12
3	SETUP	13
3.1	Generally applicable rules	13
3.2	Cabling	14
3.3	Connections	15
3.3.1	Power Supply (X1)	16
3.3.2	Digital output (X8)	16
3.3.3	Digital and analog input (X7).	18
3.3.4	CAN1, CAN2 (X11 / X12)	21
3.3.5	Ethernet (X2).	22
3.3.6	USB (X13).	23
3.3.7	Option connector (X701).	24
3.4	Configuration	24
3.4.1	DIP switches	24
3.5	Status indicators	26

READ THIS FIRST

These instructions are intended for qualified technical personnel. Prior commencing with any activities...

- you must carefully read and understand this manual and
- you must follow the instructions given therein.

The MicroMACS6 master controller is considered as partly completed machinery according to EU Directive 2006/42/EC, Article 2, Clause (g) and is intended to be incorporated into or assembled with other machinery or other partly completed machinery or equipment.

Therefore, you must not put the device into service,...

- unless you have made completely sure that the other machinery fully complies with the EU directive's requirements!
- unless the other machinery fulfills all relevant health and safety aspects!
- unless all respective interfaces have been established and fulfill the herein stated requirements!

4	MAIN WIRING DIAGRAM	27
4.1	Main wiring diagram	27
	LIST OF FIGURES	29
	LIST OF TABLES	30
	INDEX	31

1 ABOUT

1.1 About this document

1.1.1 Intended purpose

The purpose of the present document is to familiarize you with the MicroMACS6 motion controller. It will highlight the tasks for safe and adequate installation and/or commissioning. Follow the described instructions ...

- to avoid dangerous situations,
- to keep installation and/or commissioning time at a minimum,
- to increase reliability and service life of the described equipment

The present document is part of a documentation set and contains performance data and specifications, information on fulfilled standards, details on connections and pin assignment, and wiring examples. The below overview shows the documentation hierarchy and the interrelationship of its individual parts:

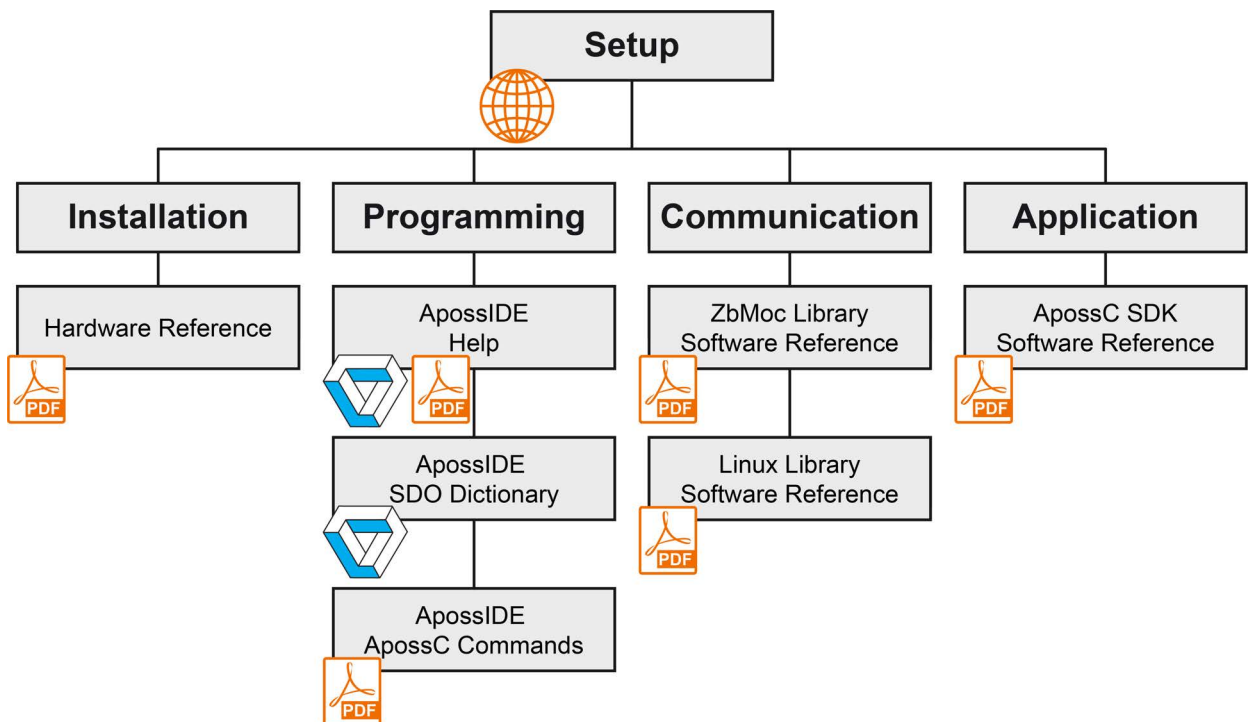

Figure 1-1 Documentation structure

1.1.2 Target audience

The present document is intended for trained and skilled personnel. It conveys information on how to understand and fulfill the respective work and duties.

1.1.3 How to use

Throughout the document, the following notations and codes will be used.

Notation	Meaning
(n)	refers to an item (such as part numbers, list items, etc.)
→	denotes “see”, “see also”, “take note of” or “go to”

Table 1-1 Notation used

1.1.4 Symbols & signs

In the course of the present document, the following symbols and signs will be used.

Type	Symbol	Meaning
Safety alert DANGER		Indicates an imminent hazardous situation . If not avoided, it will result in death or serious injury .
WARNING		Indicates a potential hazardous situation . If not avoided, it can result in death or serious injury .
CAUTION		Indicates a probable hazardous situation or calls the attention to unsafe practices. If not avoided, it may result in injury .
Prohibited action	 (typical)	Indicates a dangerous action. Hence, you must not!
Mandatory action	 (typical)	Indicates a mandatory action. Hence, you must!
Requirement, Note, Remark		Indicates an activity you must perform prior continuing, or gives information on a particular item you need to observe.
Best practice		Indicates an advice or recommendation on the easiest and best way to further proceed.
Material Damage		Indicates information particular to possible damage of the equipment.

Table 1-2 Symbols and signs

1.1.5 Trademarks and brand names

For easier legibility, registered brand names are listed below and will not be further tagged with their respective trademark. It must be understood that the brands (the list below is not necessarily concluding) are protected by copyright and/or other intellectual property rights even if their legal trademarks are omitted in the later course of this document.

Brand Name	Trademark owner
Adobe® Reader®	© Adobe Systems Incorporated, USA-San Jose, CA

Table 1-3 Brand names and trademark owners

1.1.6 Copyright

zub | MicroMACS6 master controller Hardware Reference | Edition 2024-01 | DocNr. rel12115

© 2024 maxon. All rights reserved. Any use, in particular reproduction, editing, translation and copying without prior written approval is not permitted (contact: maxon international ltd., Brünigstrasse 220, CH-6072 Sachseln, +41 41 666 15 00, www.maxongroup.com). Infringements will be prosecuted under civil and criminal law. The mentioned trademarks belong to their respective owner and are protected under trademark laws. Subject to change without prior notice.

1.2 About the device

Capabilities of the device, included features, and supported motors.

The MicroMACS6 Hardware Reference is a compact and programmable master controller with limited interfaces and functionality. It is a pure CANopen master controller without any amplifiers and able to command up to 6 axes. Further extensions to the SDK with templates and examples specifically for the MicroMACS6 are available license-free. The product is primarily a cheaper and smaller sized alternative to the MasterMACS and is lowering the entry barrier to the programming environment ApossC/ApossIDE for the maxon group.

The device is designed to be configured via simple DIP switch settings for several functions.

1.3 About the safety precautions

Keep in mind: Safety first! Always!

- Make sure that you have read and understood the note “READ THIS FIRST” auf Seite A-2!
- Do not engage with any work unless you possess the stated skills (→Kapitel “1.1.2 Target audience” auf Seite 1-6)!
- Refer to →Kapitel “1.1.4 Symbols & signs” auf Seite 1-6 to understand the subsequently used indicators!
- You must observe any regulation applicable in the country and/or at the site of implementation with regard to health and safety/accident prevention and/or environmental protection!



DANGER

High voltage and/or electric shock

Touching live wires causes death or serious injuries!

- *Consider any power cable as connected to live power, unless having proven the opposite!*
- *Make sure that neither end of cable is connected to live power!*
- *Make sure that power source cannot be engaged while work is in process!*
- *Obey lock-out/tag-out procedures!*
- *Make sure to securely lock any power engaging equipment against unintentional engagement and tag it with your name!*



Requirements

- *Make sure that all associated devices and components are installed according to local regulations.*
- *Be aware that, by principle, an electronic apparatus cannot be considered fail-safe. Therefore, you must make sure that any machine/apparatus has been fitted with independent monitoring and safety equipment. If the machine/apparatus should break down, if it is operated incorrectly, if the control unit breaks down or if the cables break or get disconnected, etc., the complete drive system must return – and be kept – in a safe operating mode.*
- *Be aware that you are not entitled to perform any repair on components supplied by maxon.*



Electrostatic sensitive device (ESD)

- *Wear working cloth and use equipment in compliance with ESD protective measures.*
- *Handle device with extra care.*

2 SPECIFICATIONS

2.1 Technical data

MicroMACS6 master controller (001794)		
Electrical Rating	Nominal power supply voltage +V _{CC}	10 ...24 VDC
	Absolute power supply voltage +V _{min} / +V _{max}	8 VDC / 28 VDC
	Supply current without I/O loads	typically 35 mA @ 24 V
Memory	Program memory	16 Mbyte Flash
Inputs & output	Digital Input 1 (general purpose)	DIP Switch-selectable levels: • Logic: +2.0...+30 VDC • PLC: +9.0...+30 VDC
	Digital Input 2 (general purpose)	
	Digital Input 3 (general purpose)	
	Digital Input 4 (general purpose)	
	Digital Input 5 (general purpose)	
	Digital Input 6 (general purpose)	
	Digital Output 1 (general purpose)	25 kHz; PWM duty cycle range 2 ... 98 %
	Digital Output 2 (general purpose)	
	Digital Output 3 (general purpose)	
	Digital Output 4 (general purpose)	
	Analog Input 1	Resolution 12-bit, 0...+10 V
	Analog Input 2	
Interfaces	Ethernet	Ethernet TCP/IP max. 100 MBaud
	CAN 1	max. 1 MBaud, master/slave DIP switch-selectable termination resistor and CAN ID
	CAN 2	max. 1 MBaud, master DIP switch-selectable termination resistor
	USB 2.0	High speed
	BLE	Prepared mounting a BLE option
Configuration	DIP switches	SMD type, 8 position, setting of: CAN2 ID, CAN1, CAN2 termination resistor, digital inputs DigIN 1-3 logic or PLC mode, digital inputs DigIN 4-6 logic or PLC mode
Status indicator	Device Status	Operation (green) Error (red) Status (yellow)
Physical	Weight	approximate 26 g
	Dimensions (L x W x H)	53.8 mm x 38.8 mm x 20.65 mm
	Mounting	Flange for M 2.5 screws

Continued on next page.

MicroMACS6 master controller (001794)			
Environment	Temperature	Operation	-30...+55 °C
		Storage	-40...+85 °C
	Altitude [a]	Operation	0...6'000 m MSL
	Humidity	5...90 % (condensation not permitted)	

[a] Operating altitude in meters above mean sea level, MSL

Table 2-4 Technical data

2.2 Limitations

Protection functionality	Switch-off threshold	Recovery threshold
Undervoltage	7.5 V	8.0 V
Overvoltage	32 V	29 V

Table 2-5 Limitations

2.3 Dimensional drawings

2.3.1 MicroMACS6 (001794)

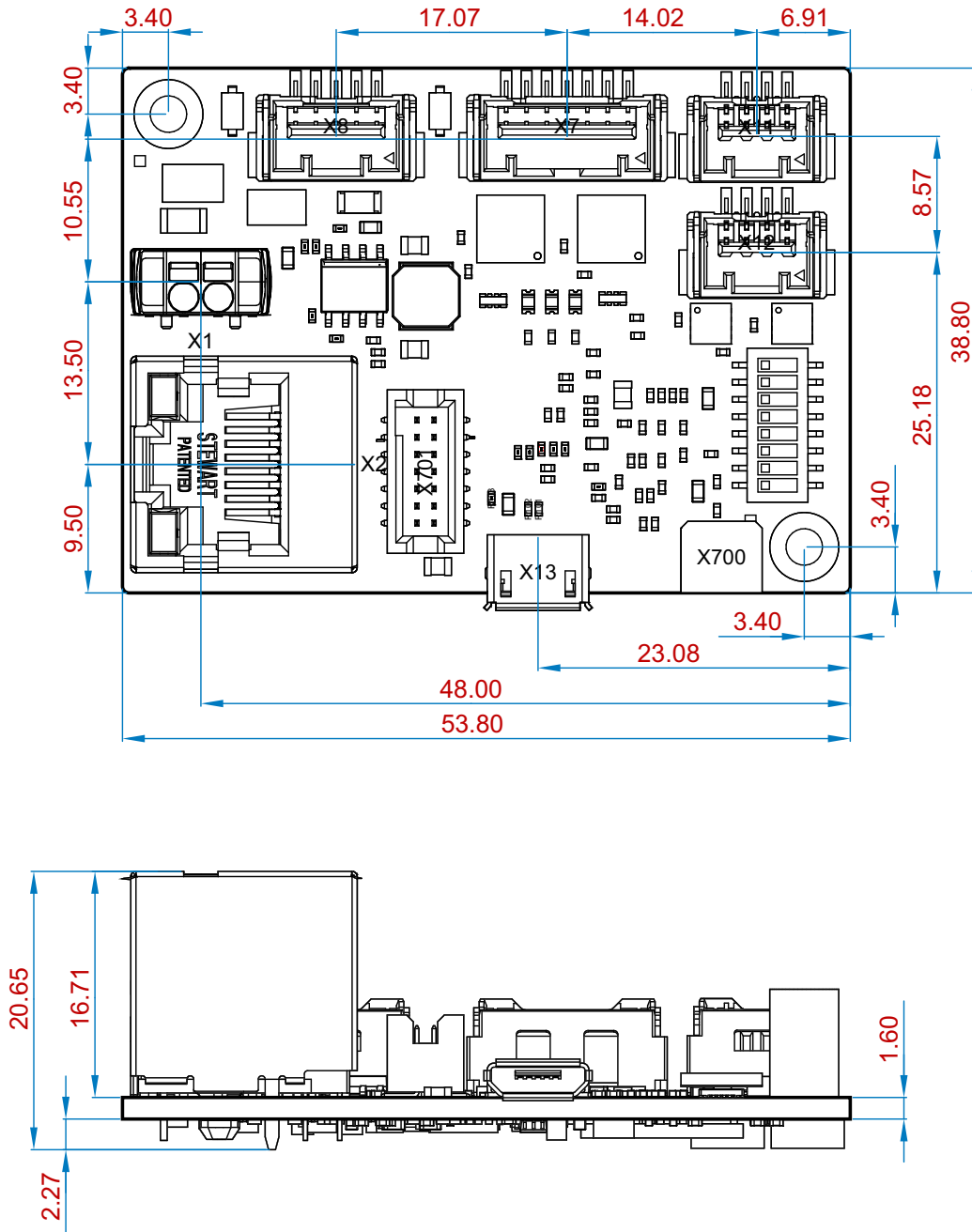

Figure 2-2 MicroMACS6 (001794) – dimensional drawing [mm]

2.4 Standards

The described device is successfully tested for compliance with the below listed standards. In practical terms, only the complete system (the fully operational equipment comprising all individual components, such as motor, servo controller, power supply unit, EMC filter, cabling etc.) can undergo an EMC test to ensure interference-free operation.



Important notice

The device's compliance with the mentioned standards does not imply its compliance within the final, ready to operate setup. In order to achieve compliance of your operating system, you must perform EMC testing of the involved equipment as a whole

Electromagnetic compatibility (under development)		
Generic	IEC/EN 61000-6-2	Immunity for industrial environments
	IEC/EN 61000-6-3	Emission standard for residential, commercial and light-industrial environments
Applied	CISPR11:2015	Terminal disturbance voltages / Electromagnetic radiation disturbance
	IEC/EN 61000-4-3	Radiated, radio-frequency, electromagnetic field immunity test >10 V/m
	IEC/EN 61000-4-4	Electrical fast transient/burst immunity test ±2 kV
	IEC/EN 61000-4-6	Immunity to conducted disturbances, induced by radio-frequency fields 10 Vrms
Reliability	MIL-HDBK-217F	Reliability prediction of electronic equipment Environment: Ground, benign (GB) Ambient temperature: 298 K (25 °C) Component stress: Nominal power Mean Time Between Failures (MTBF) • MicroMACS6: 907'067 hours

Table 2-6 Standards

3 SETUP

IMPORTANT NOTICE: PREREQUISITES FOR PERMISSION TO COMMENCE INSTALLATION

The MicroMACS6 master controller is considered as partly completed machinery according to EU Directive 2006/42/EC, Article 2, Clause (g) and **intends to be incorporated into or assembled with other machinery or other partly completed machinery or equipment.**



WARNING

Risk of injury

Operating the device without the full compliance of the surrounding system with the EU directive 2006/42/EC may cause serious injuries!

- Do not operate the device, unless you have made completely sure that the other machinery fully complies with the EU directive's requirements!
- Do not operate the device, unless the other machinery fulfills all relevant health and safety aspects!
- Do not operate the device, unless all respective interfaces are established and fulfill the requirements stated in this document!

3.1 Generally applicable rules



Maximal permitted supply voltage

- Make sure that supply power is between 10...24 VDC.
- Supply voltages above 28 VDC will destroy the unit.



Hot plugging the USB interface may cause hardware damage

If the USB interface is being hot-plugged (connecting while the power supply is on), the possibly high potential differences of the two power supplies of controller and PC/Notebook can lead to damaged hardware.

- Avoid potential differences between the power supply of controller and PC/Notebook or, if possible, balance them.
- Insert the USB connector first, then Switch on the power supply of the controller.



Hot plugging/hot swapping the extension slots may cause hardware damage

- Switch off the controller's power supply before removing or inserting an extension card.

3.2 Cabling

PLUG&PLAY

Take advantage of maxon's prefab cable assemblies. These cables come as ready-to-use parts and will help to reduce commissioning time to a minimum.

- a) Check the following table and find the part number of the cable assembly that matches the setup you will be using.
- b) Follow the cross-reference to get the cable's pin assignment.

Connector	Prefab cable assembly		
	Designation	Part number	→Page
X2	Ethernet cable	422827	3-22
X7	Digital and analog input cable	520854	3-18
X8	Digital output cable	786774	3-18
X11 / X12	CAN1, CAN2 cable	520858	3-24
X13	Ethernet cable	403968	3-22

Table 3-7 Prefab maxon cables

MAKE&BAKE YOUR OWN

If you decide not to employ maxon's prefab cable assemblies, you might wish to use the prepackaged kit that contains all connectors required to make up your own cabling.

MicroMACS6 connector set (786794)		
Connector	Specification	Quantity
Connectors		
X7	Molex CLIK-Mate, single row, 7 poles (502578-0700)	1
X8	Molex CLIK-Mate, single row, 5 poles (502578-0500)	1
X11 / X12	Molex CLIK-Mate, single row, 4 poles (502578-0400)	2
Crimp terminal		
	Molex CLIK-Mate Crimp terminal (502579-0100)	20

Table 3-8 MicroMACS6 Connector Set - Content

TOOLS

Tool	Manufacturer	Part number
Hand crimper for CLIK-Mate crimp terminals	Molex	2002187400

Table 3-9 Recommended tools

3.3 Connections

The actual connection will depend on the overall configuration of your drive system and the type and number of motors you will be using. For each connector you will find detailed information on the pin assignment. Available accessories and prefab cable assemblies, circuitry, and requirements that must be met, if any.



How to read pin assignment tables

In the later course of the document you will find tables containing information on the hardware connectors, their wired signals and assigned pins as well as details on the available prefab cables.

- The first column describes both the pin number of the connector and of the matching prefab maxon cable's Head A.
- The second column describes the cable core color of the prefab maxon cable.
- The third column describes the pin number of the prefab maxon cable's Head B.

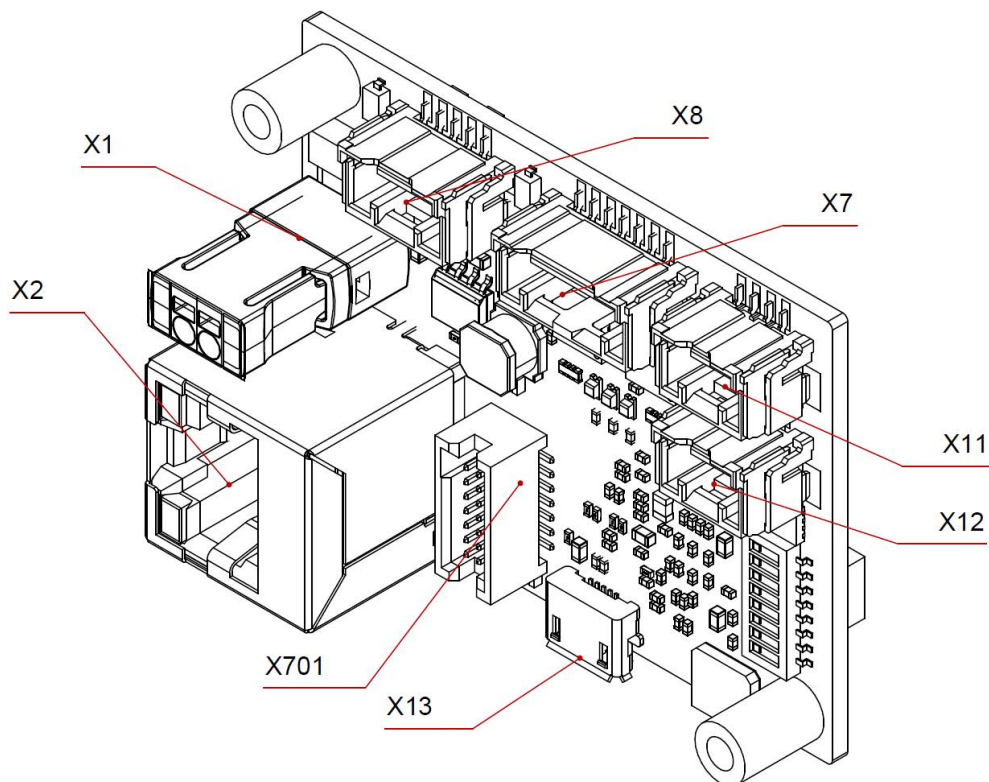

X1	Power Supply →Seite 3-16
X2	Ethernet →Seite 3-22
X7	Digital and analog input →Seite 3-18
X8	Digital outputs →Seite 3-18
X11	CAN1 →Seite 3-21
X12	CAN2 →Seite 3-21
X13	USB →Seite 3-23
X701	Option connector →Seite 3-24

Figure 3-3 Connectors overview

3.3.1 Power Supply (X1)

Basically, any power supply can be used provided that it meets the stated minimum requirements.

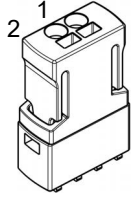

Figure 3-4 Power supply connector X1

Pin	Signal	Description
1	+V _{CC}	Power supply voltage (+8...+28 VDC)
2	GND	Ground

Table 3-10 Power supply (X1) – pin assignment

Power supply requirements X1	
Output voltage	+V _{CC} 10...24 VDC
Suitable plug	Harting pitch spring, plug 2P 160V 6A 2.54 mm (14 31 021 3101 000) —included with every Compact version delivery—
Absolute output voltage	min. 8 VDC; max. 28 VDC
Output current	Depending on digital outputs load • continuous max. 0.5 A

Table 3-11 Power & logic supply combo connector X1/X2 – Specification and accessories

3.3.2 Digital output (X8)

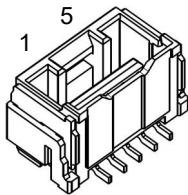

Figure 3-5 Digital outputs connector X8

Head A Pin	Prefab cable Color	Head B Pin	Signal	Description
1	white	1	DigOUT1	Digital Output 1
2	brown	2	DigOUT2	Digital Output 2
3	green	3	DigOUT3	Digital Output 3
4	yellow	4	DigOUT4	Digital Output 4
5	grey	5	GND	Ground

Table 3-12 Digital output connector (X8) – pin assignment

Signal cable 5 core (786774)			
A			B
Cross-section	5 x 0.14 mm ² , grey		
Length	3 m		
Head A	Plug	Molex CLIK-Mate, single row, 5 poles (502578-0500)	
	Contacts	Molex CLIK-Mate crimp terminals (502579)	
Head B	Wire end sleeves 0.14 mm ²		

Table 3-13 Signal cable 5core



Note: When operating the MicroMACS6 in an EMV contaminated environment, the input and output cables must be filtered with a ferrite or shielded cables must be used.

Digital Output	
Output voltage	+V _{CC}
Max. output current	100 mA
Max. output frequency	25 kHz; PWM duty cycle range 2 ... 98 %

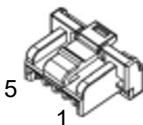
Table 3-14 Digital output specification

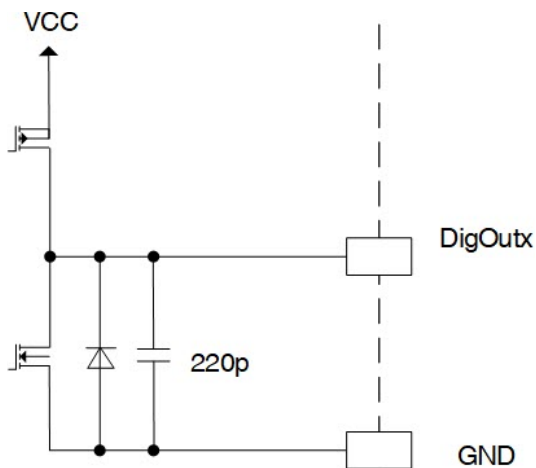

Figure 3-6 Digital output circuit

3.3.3 Digital and analog input (X7)

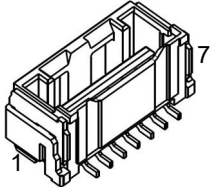

Figure 3-7 Digital input connector X7

Head A Pin	Prefab cable Color	Head B Pin	Signal	Description
1	white	1	DigIN1	General purpose
2	brown	2	DigIN2	General purpose
3	green	3	DigIN3	General purpose
4	yellow	4	DigIN4 / AnIN2	Digital input general purpose / analog input 2
5	grey	5	DigIN5 / AnIN1	Digital input general purpose / analog input 1
6	pink	6	DigIN6	General purpose
7	blue	7	GND	Ground

Table 3-15 Digital and analog input (X7) – pin assignment

Signal cable 7core (520854)		
Cross-section	7 x 0.14 mm ² , grey	
Length	3 m	
Head A	Plug	Molex CLIK-Mate, single row, 7 poles (502578-0700)
	Contacts	Molex CLIK-Mate crimp terminals (502579)
Head B	Wire end sleeves 0.14 mm ²	

Table 3-16 Signal cable 7core



Note: When operating the MicroMACS6 in an EMV contaminated environment, the input and output cables must be filtered with a ferrite or shielded cables must be used.

Digital inputs 1 ... 6 (logic level setting)	
Input voltage	0 ... 30 VDC
Max. input voltage	±30 VDC
Logic 0	<0.8 V
Logic 1	>2.0 V
Input current at logic 1	255 µA @ 5 VDC
Switching delay	<300 µs @ 5 VDC (Sampling rate firmware 1kHz)

Table 3-17 Digital input specification - logic level settings

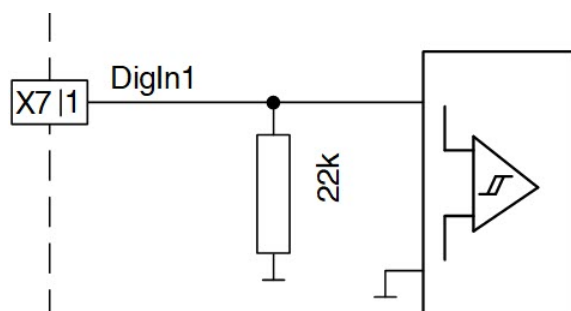

Figure 3-8 DigIN 1 circuit (analogously valid for DigIN 2, DigIN 3, DigIN 6) logic level setting

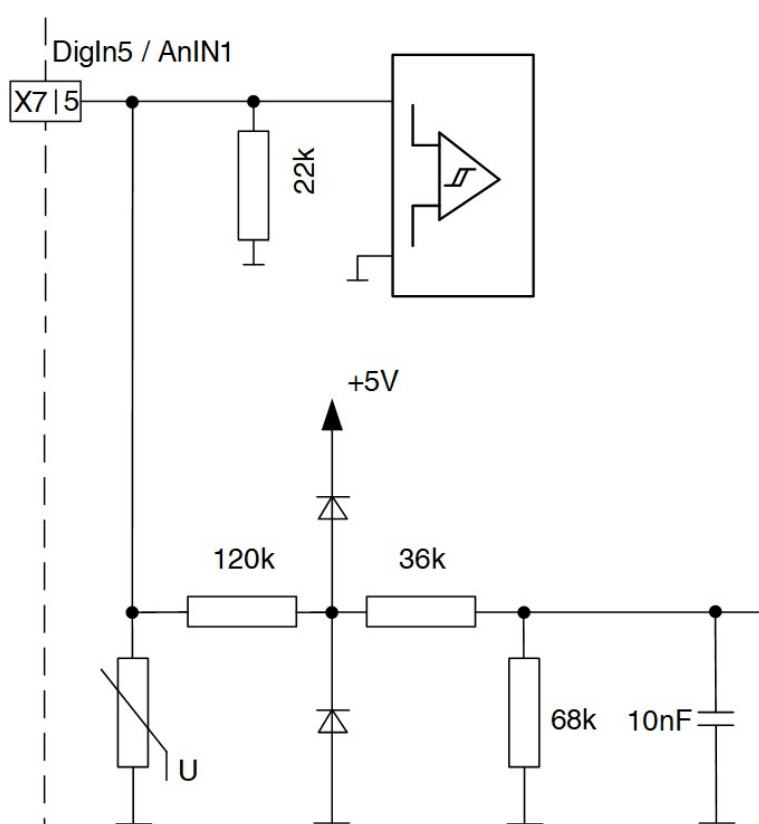

Figure 3-9 DigIN 5 / AnIN1 circuit (analogously valid for DigIN 4 / AnIN2) logic level setting

Digital inputs 1 ... 6 (PLC level setting)	
Input voltage	0 ... 30 VDC
Max. input voltage	±30 VDC
Logic 0	<5.5 V
Logic 1	>9 V
Input current at logic 1	>2 mA @ 9 VDC typically 3.5 mA @ 24 VDC
Switching delay	<300 μs @ 24 VDC (Sampling rate firmware 1kHz)

Table 3-18 Digital input specification - PLC level setting

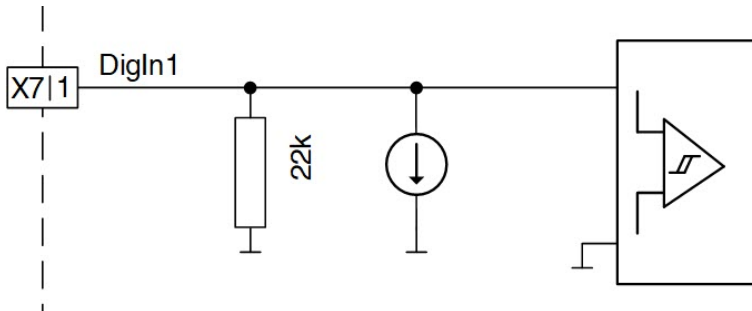

Figure 3-10 DigIn 1 circuit (analogously valid for DigIn 2, DigIn 3, DigIn 6) PLC level setting

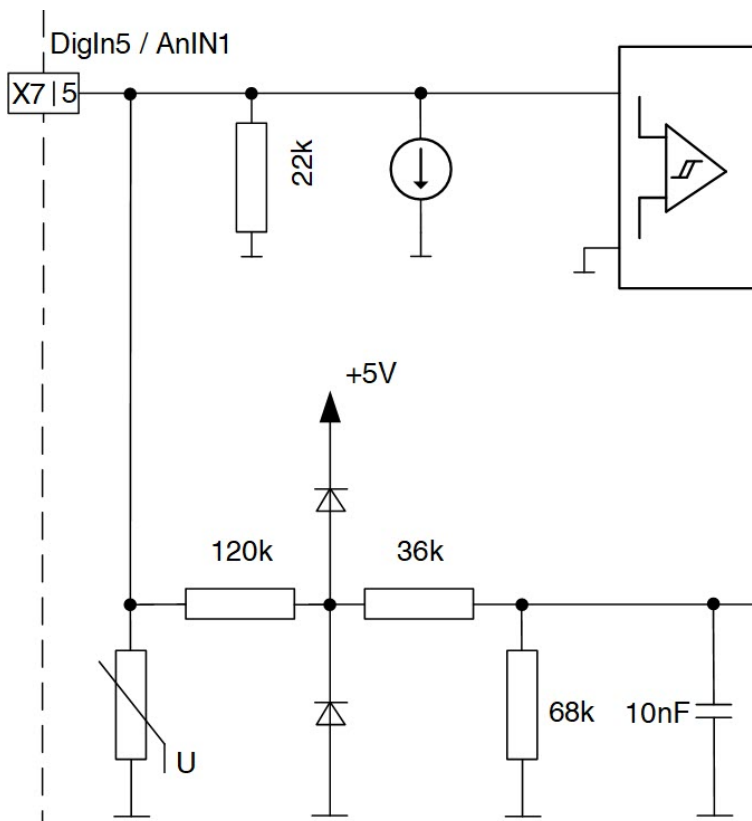

Figure 3-11 DigIn 5 / AnIN1 circuit (analogously valid for DigIn 4 / AnIN2) PLC level setting

Analog inputs AnIN1, AnIN2 (only logic level setting allowed) [2]	
Input voltage	+10 VDC
Max. input voltage	±30 VDC
Input resistance	20 kΩ
A/D converter	12 Bit
Resolution	2.654 mV
Bandwidth	336 Hz

Table 3-19 Digital input specification - PLC level setting

[2] Operation of the analog inputs is only in logic level mode possible.

3.3.4 CAN1, CAN2 (X11 / X12)

CAN2 is used as CAN-Master and CAN1 is used as CAN-Slave and CAN-Master in the CANopen network. The DIP switches are in use to configure the CAN ID of CAN1 and bus termination.

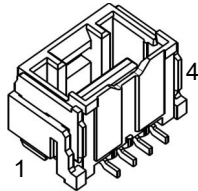

Figure 3-12 CAN1 CAN2 connector X11, X12

Pin	Signal	Description
1	CAN high	CAN high bus line
2	CAN low	CAN low bus line
3	GND	Ground
4	Shield	Cable shield

Table 3-20 CAN connectors (X11, X12) – pin assignment

The CAN node ID of CAN1 has to be configured by the DIP switches 1 – 3. The DIP switch 5 – 6 activates / deactivates the bus termination of the CAN1 and CAN2 bus.

CAN interface	
Standard	ISO 11898-2:2003
Max. bit rate	1 Mbit/s
Protocol	CiA 301
Node-ID setting CAN1	By DIP switch
Termination	By DIP switch

Table 3-21 CAN1 CAN2 interface specification

CAN-CAN cable (520858)		
<div style="display: flex; justify-content: space-between; align-items: center;"> <div style="text-align: center;"> <p>A</p> </div> <div style="text-align: center;"> <p>B</p> </div> </div>		
Cross-section	2 x 2 x 0.14 mm ² , twisted pair, shielded	
Length	3 m	
Head A	Plug	Molex CLIK-Mate, single row, 4 poles (502578-0400)
	Contacts	Molex CLIK-Mate crimp terminals (502579)
Head B	Plug	Molex CLIK-Mate, single row, 4 poles (502578-0400)
	Contacts	Molex CLIK-Mate crimp terminals (502579)

Table 3-22 CAN-CAN cable

3.3.5 Ethernet (X2)



Wrong plugging may cause hardware damage

- Use only standard Cat5 cables with RJ45 plug, such as maxon's «Ethernet cable» (422827).

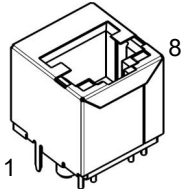

Figure 3-13 Ethernet connector X2

X2 HEAD A Pin	Cable color	HEAD B Pin	Signal	Description
1	white / orange	1	TX+	Transmit exchange +
2	orange	2	TX-	Transmit exchange -
3	white / green	3	RX+	Receiver exchange +
4	blue	4		
5	white / blue	5		
6	green	6	RX-	Receiver exchange -
7	white / brown	7		
8	brown	8		

Table 3-23 Ethernet connector (X2) – pin assignment

Ethernet interface	
Protocol	Ethernet TCP/IP
Max. bit rate	Max. 100MBaud

Table 3-24 Ethernet specification

Ethernet cable (422827)	
Cross-section	Cat. 5e SF/UTP (ISO/IEC 11801), 1:1 patch cable, green
Length	2 m
Head A	RJ45 (8P8CS) EIA/TIA-568B
Head B	RJ45 (8P8CS) EIA/TIA-568B

Table 3-25 Ethernet cable

3.3.6 USB (X13)



Hot plugging the USB interface may cause hardware damage

If the USB interface is being hot-plugged (connecting while the power supply is on), the possibly high potential differences of the two power supplies of controller and PC/Notebook can lead to damaged hardware.

- Avoid potential differences between the power supply of controller and PC/Notebook or, if possible, balance them.
- Insert the USB connector first, then Switch on the power supply of the controller.

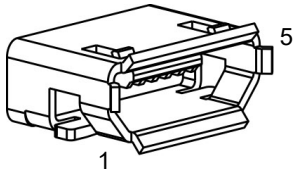

Figure 3-14 USB connector X13

Pin	Signal	Description
1	V _{BUS}	USB bus supply voltage input + 5 VDC
2	USB_D-	USB data - (twisted pair with data+)
3	USB_D+	USB data + (twisted pair with data-)
4		ID, not connected
5	GND	USB ground

Table 3-26 USB Connector (X13) - pin assignment

USB Type A - micro B Cable (403968)	
Cross-section	According to USB 2.0 / USB 3.0 specification
Length	1.5 m
Head A	USB Type "micro B", male
Head B	USB Type "A", male

Table 3-27 USB 1 Type A - micro B cable

3.3.7 Option connector (X701)

The X701 connector acts as an option connector for future options. It features SPI, UART, I2C, CAN and all the power levels from the main board.

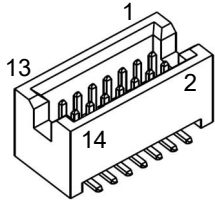

Figure 3-15 Option connector X701

Pin	Signal	Description
1	OPTION_I2C_SCL	I2C serial clock
2	OPTION_I2C_SDA	I2C serial data
3	CAN1option_H	CAN high bus line
4	CAN1option_L	CAN low bus line
5	+3.3 V	+3.3 V supply voltage
6	+24 V	+V _{CC} power supply voltage (+8 VDC ... +28 VDC)
7	GND	Ground
8	+5 V	+5 V supply voltage
9	OPTION_SPI_SCK	SPI serial clock
10	OPTION_SPI_SDO	SPI serial data out
11	OPTION_SPI_SDI	SPI serial data in
12	OPTION_SPI_CS	SPI chip select
13	OPTION_UART_RX	UART receive
14	OPTION_UART_TX	UART transmit

Table 3-28 Option connector (X701) – pin assignment

3.4 Configuration

3.4.1 DIP switches

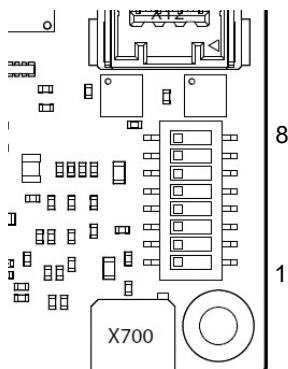

Figure 3-16 DIP switches - location

The device's functionality is set by DIP switches 1...8

Setting	Switch			CAN1 ID
	1	2	3	
0 (default)	OFF	OFF	OFF	-
1	ON	OFF	OFF	1
2	OFF	ON	OFF	2
3	ON	ON	OFF	3
4	OFF	OFF	ON	4
5	ON	OFF	ON	5
6	OFF	ON	ON	6
7	ON	ON	ON	7

Table 3-29 DIP switch 1 - 4: CAN1 ID selection

Switch	Functionality	OFF (default)	ON
4	Boot mode	Boot from fuses	Internal boot

Table 3-30 DIP switch 5: Boot mode selection

Switch	Functionality	OFF (default)	ON
5	CAN2 termination	deactivated	activated
6	CAN1 termination	deactivated	activated

Table 3-31 DIP switch 6 - 7: CAN termination

Switch	Functionality	OFF (default)	ON
7	Digital input level DigIN 4 / AnIN2, DigIN 5 / AnIN1, DigIN6	Logic level	PLC level

Table 3-32 DIP switch 7: Digital input level

Switch	Functionality	OFF (default)	ON
8	Digital input level DigIN1, DigIN2, DigIN3	Logic level	PLC level

Table 3-33 DIP switch 8: Digital input level

3.5 Status indicators

The MicroMACS6 master controller features a set of LED indicators to display the Device status.

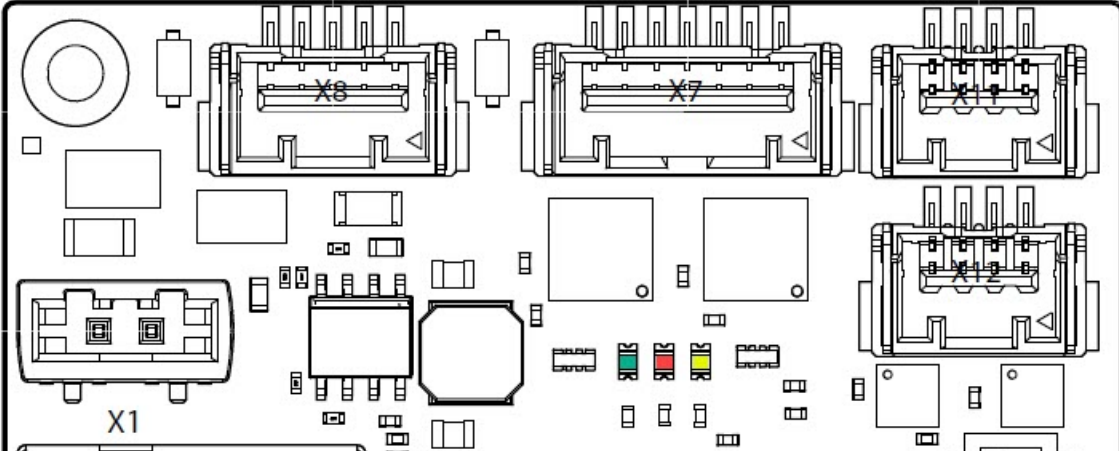

Figure 3-17 LEDs – location

- Green LED shows operating status
- Red LED indicates error
- Yellow LED indicates status

LED	Status	Description
1 Green	ON	Power supply in range, firmware is running
2 Red	ON	An error occurred
5 Yellow	ON	User application is running. Power supply in range, firmware is running.

Table 3-34 Device status LED

4 MAIN WIRING DIAGRAM

4.1 Main wiring diagram



Load capacity of the sensor supply

The maximum load of the sensor supply is 1 A for the total of all Hall sensors and encoders combined.

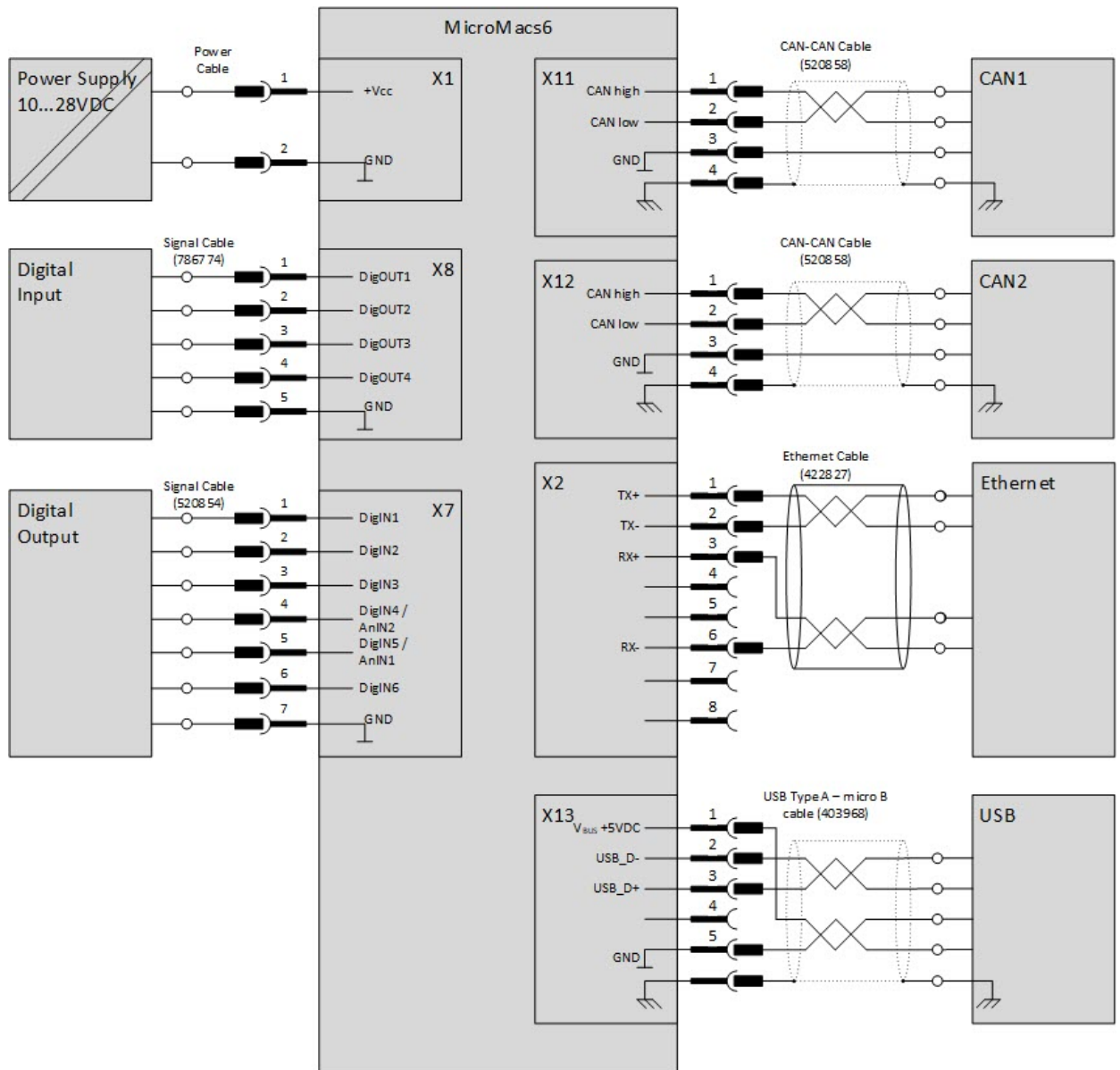

Figure 4-18 Main wiring diagram

••page intentionally left blank••

LIST OF FIGURES

Figure 1-1	Documentation structure	5
Figure 2-2	MicroMACS6 (001794) – dimensional drawing [mm]	11
Figure 3-3	Connectors overview.	15
Figure 3-4	Power supply connector X1.	16
Figure 3-5	Digital outputs connector X8	16
Figure 3-6	Digital output circuit.	17
Figure 3-7	Digital input connector X7	18
Figure 3-8	DigIN 1 circuit (analogously valid for DigIN 2, DigIN 3, DigIN 6) logic level setting	19
Figure 3-9	DigIN 5 / AnIN1 circuit (analogously valid for DigIN 4 / AnIN2) logic level setting	19
Figure 3-10	DigIN 1 circuit (analogously valid for DigIN 2, DigIN 3, DigIN 6) PLC level setting.	20
Figure 3-11	DigIN 5 / AnIN1 circuit (analogously valid for DigIN 4 / AnIN2) PLC level setting.	20
Figure 3-12	CAN1 CAN2 connector X11, X12	21
Figure 3-13	Ethernet connector X2.	22
Figure 3-14	USB connector X13.	23
Figure 3-15	Option connector X701	24
Figure 3-16	DIP switches - location	24
Figure 3-17	LEDs – location	26
Figure 4-18	Main wiring diagram	27

LIST OF TABLES

Table 1-1	Notation used	6
Table 1-2	Symbols and signs	6
Table 1-3	Brand names and trademark owners	7
Table 2-4	Technical data	10
Table 2-5	Limitations	10
Table 2-6	Standards	12
Table 3-7	Prefab maxon cables	14
Table 3-8	MicroMACS6 Connector Set - Content	14
Table 3-9	Recommended tools	14
Table 3-10	Power supply (X1) – pin assignment	16
Table 3-11	Power & logic supply combo connector X1/X2 – Specification and accessories	16
Table 3-12	Digital output connector (X8) – pin assignment	16
Table 3-13	Signal cable 5core	17
Table 3-14	Digital output specification	17
Table 3-15	Digital and analog input (X7) – pin assignment	18
Table 3-16	Signal cable 7core	18
Table 3-17	Digital input specification - logic level settings	18
Table 3-18	Digital input specification - PLC level setting	19
Table 3-19	Digital input specification - PLC level setting	20
Table 3-20	CAN connectors (X11, X12) – pin assignment	21
Table 3-21	CAN1 CAN2 interface specification	21
Table 3-22	CAN-CAN cable	21
Table 3-23	Ethernet connector (X2) – pin assignment	22
Table 3-24	Ethernet specification	22
Table 3-25	Ethernet cable	22
Table 3-26	USB Connector (X13) - pin assignment	23
Table 3-27	USB 1 Type A - micro B cable	23
Table 3-28	Option connector (X701) – pin assignment	24
Table 3-29	DIP switch 1 - 4: CAN1 ID selection	25
Table 3-30	DIP switch 5: Boot mode selection	25
Table 3-31	DIP switch 6 - 7: CAN termination	25
Table 3-32	DIP switch 7: Digital input level	25
Table 3-33	DIP switch 8: Digital input level	25
Table 3-34	Device status LED	26

INDEX

A

alerts 6
 applicable EU directive 13
 applicable regulations 8

C

cables (prefab)
 CAN-CAN Cable 21
 Power Cable 17
 Sensor Cable 5x2core 22, 23
 Signal Cable 7core 18

connectors

X1 16
 X1/X2 16
 X10, X20, X30, X40 18
 X11, X21, X31, X41 21
 X12, X22, X32, X42 22
 X5, X6 23
 X7 24

country-specific regulations 8

D

device condition, display of 26
 digital incremental encoder (differential) 22
 DIP switch SW1 24

E

ESD 8
 EU directive, applicable 13

H

how to
 interpret icons (and signs) used in this document 6

I

incorporation into surrounding system 13
 informatory signs 6
 interfaces

 location and designation 15, 16, 17, 18, 19, 20, 21, 22,
 23, 24

L

LEDs, interpretation of 26

M

mandatory action signs 6
 MiniMACS6 AMP-4/50/10 Connector Set 14

N

notations used 6

O

operating license 13

P

part numbers
 001772 14
 275829 17
 520852 22, 23

520854 18

520858 21

performance data 9
 power supply requirements 16
 precautions 8
 prerequisites prior installation 13
 prohibitive signs 6
 protective measures (ESD) 8
 purpose
 of the device 7
 of the document 5

R

recommended tools 14
 regulations, applicable 8
 requirements of power supply 16

S

safety alerts 6
 signs used 6
 standards, fulfilled 12
 status LEDs 26
 symbols used 6

T

technical data 9
 tools, recommended 14

